

LFS-02F



Specifications

Capacity	0 ~ 1, 2, 3, 5kg
Material	Stainless Steel
Rated Output	2.0 ± 10% mV/V
Zero Balance	± 2 % F.S.
Non-linearity	± 0.05% F.S.
Hysteresis	± 0.05% F.S.
Repeatability	± 0.05% F.S.
Creep (30min)	± 0.05% F.S.
Temp. Effect on Output	± 0.05% F.S. / 10°C
Temp. Effect on Zero	± 0.05% F.S. / 10°C
Input Impedance	350 ± 10 Ω
Output Impedance	350 ± 10 Ω
Insulation	≥5000M Ω /100VDC
Recommended Excitation	3 ~ 5V
Operating Temp. Range	- 20 ~ 80 °C
Compensated Temp. Range	- 10 ~ 60 °C
Safe Overload	150%
Maximum Overload	300%
Cable Specifications	Ø 2 x 3mm
Protection Class	IP65
TEDS Available	

Load Direction

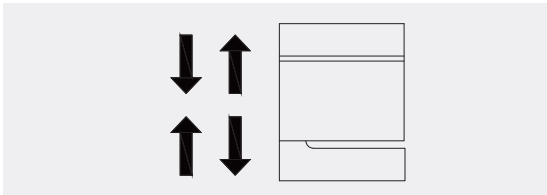

Product Dimension

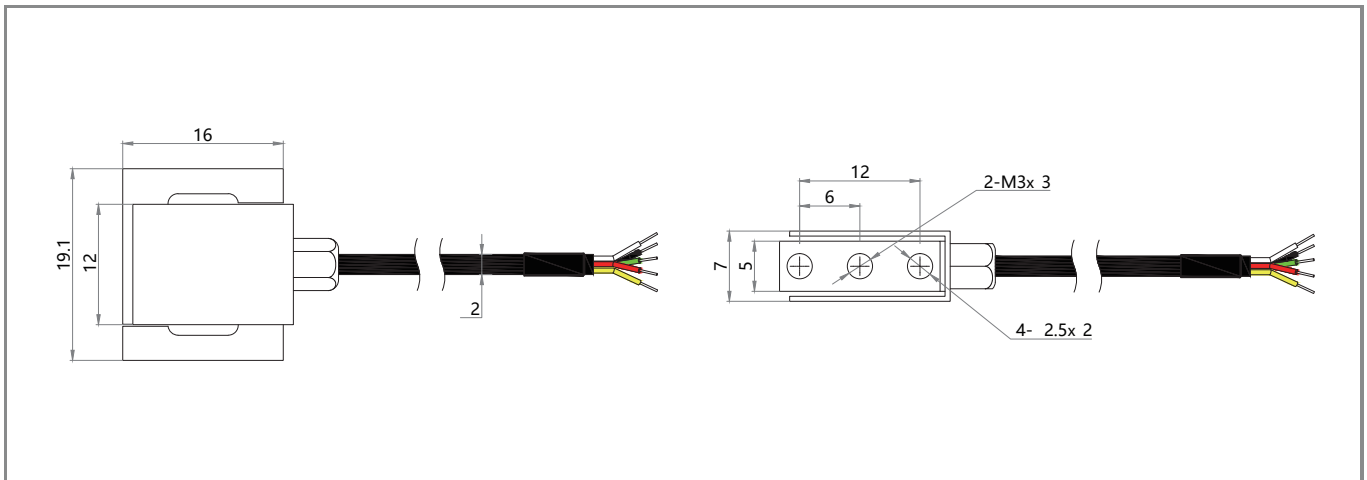

Wiring Diagram

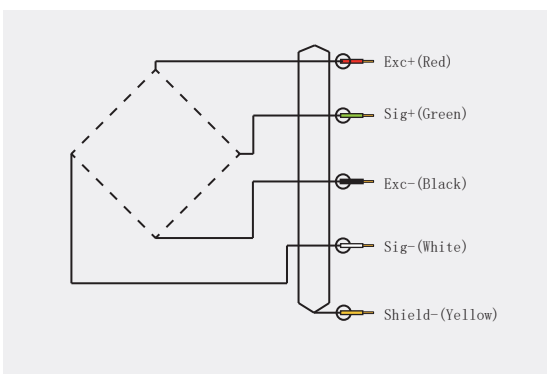

Installation Mode

